

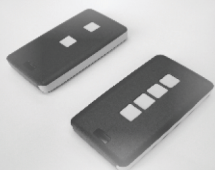

RS-1 CONTROL UNIT



DECO-2 DECO-4



TAG-4
TAG-2



PHOTOELECTRIC
CELL SAFETY SYSTEM



ANSA
ROLL-SMART



ALARM KIT



WIRELESS RADIO CODE SWITCH



WIRELESS RADIO KEY SWITCH



GLIDEROL
GARAGE DOORS

RS- I Roll-Smart Roller Door Remote Control System



Installation & Operating Instructions

V10 Roll-Smart
May 2018

ANSA RS-I Roller Door Remote Control System

Contents

1	General Description	9	Commissioning
2	General Operation	10	Adding transmitters & wireless access controls
2.2	Multi Channel Keyfobs	11	Deleting transmitters & wireless access controls
2.3	Receiver Unit Features	12	Multi- door control
3	Fitting the RS-I control unit	13	Holiday Mode
4	Electrical Connections	14	Fault diagnostic system
5	RS-I Control Board Overview & Wiring Schemes	15	Dip Switch options & Special settings
6	Roll-Smart System (optional)	16	Problem solving guide
7	Photoelectric cell safety system (optional)	17	Technical specifications
8	AL-18 Alarm System (optional)		

Installation instructions

Please read these instructions carefully prior to commencing installation of the unit. Operate unit only when the door is in full view and free from any obstruction. No one should enter or leave the garage while the door is in motion.

This booklet covers RS-I units manufactured from 01.05.2018 having the PCB identification RS1 RA/PG (See figure 8)

NOTE TO INSTALLER - PLEASE ENSURE THIS MANUAL REMAINS WITH THE END USER AS IT CONTAINS IMPORTANT SAFETY INFORMATION. PLEASE ALSO COMPLETE THE INSTALLATION DETAILS ON THE BACK PAGE

I - General Description

The ANSA RS-I control unit is designed to operate roller garage doors fitted with single phase tubular motor drives. Equipped with “rolling code” high security remote controls, allowing easy memorisation of up to 27 transmitters. The unit has all the features needed for efficient, safe and reliable operation of roller doors including built-on courtesy lamp, operating button and multi- function red indicator LED. This guide includes information on ANSA Roll-Smart System, ANSA Photoelectric Safety Beams, ANSA Alarm System and popular ANSA access controls.

2 General Operation

Your door dupliplier will recommend the ideal combination of access control and safety options to suit each installation and program the system accordingly. As a guide, the general operation for a fully commissioned door is as follows:

2.1 Keyfob Transmitter Operation

- To open the door, press the button on the keyfob transmitter for one second. The door will fully open and stop automatically at the fully open position.
- To close the door, press the button on the keyfob transmitter for one second. The door will fully close and stop automatically at the fully closed position.
- Pressing the button during a door opening or closing operation will instantly stop the door and pushing the button again for one second will reverse the original direction.
- Please note that a delay of one second is built into the operation. Allow for this delay after operating the keyfob transmitter

2.2 Multi Channel Keyfobs

Multi Channel Keyfobs use one button per door, enabling control of up to 4 garage doors from one keyfob transmitter. These are available on request.

Additional remote control receiver modules are also available to control automatic gate systems, driveway lighting and other equipment from ANSA Multi Channel Keyfobs.

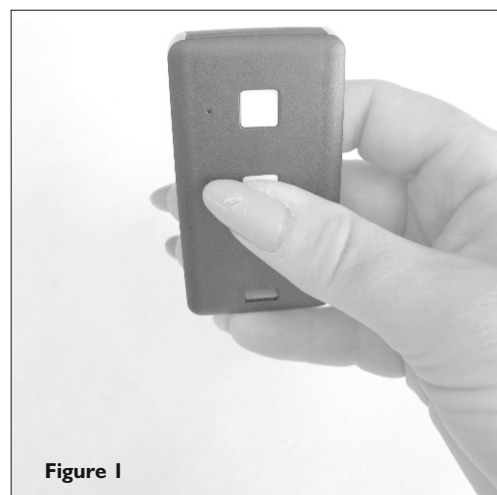

2.3 Receiver Unit Features

- The Receiver Unit has a built-in Control button which functions in the same way as the Keyfob Transmitter button.
- The Receiver has a built on courtesy light which will switch on for 3½ minutes whenever the door is operated and turn off automatically.
- The receiver mounted red LED is a multifunction indication light, flashing rapidly when the photocell or light grid system is blocked and flashing slowly for fault detection.

2.4 Hold To Run Close Facility

Hold to run is also a control option for doors not requiring the Roll-Smart or photoelectric cell safety systems. Alternatively, in the event of a problem developing in the safety system, preventing normal closure of the door (indicated by a rapidly flashing RS- I red LED). Please use the following procedure ensuring the door is in full view.

- Press the keyfob operation button or RS- I operation button for one second to open the door or stop an opening door.
- To close the door - press and hold a button continuously and after 3 seconds the door will start to close. Closure is only possible if the button is held continuously and it will stop if the button is released, requiring the full sequence to be repeated.

Please note - Do not use the Hold To Run facility if the red LED indicator is on continuously.

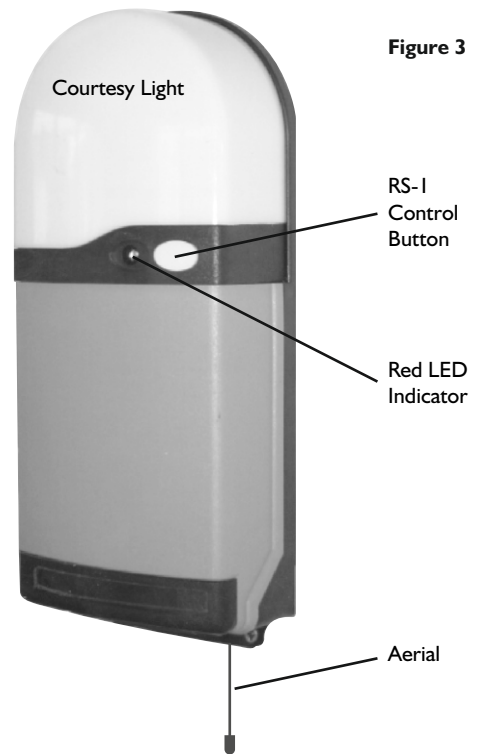

Figure 3

2.5 Using Additional Access Controls



Figure 4
DK-14
Wireless
Code Switch

DK-14 is a weatherproof High security code switch to operate your door from outside your garage.

Simply enter a secure 4 digit 'PIN' personal access code to operate your door.

The unit has blue illuminated keys for easy operation at night

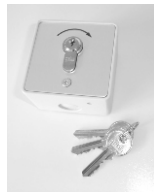

Figure 5
WK-1
Wireless
Key Switch

WK-1 is a weatherproof High security key switch to operate your door from outside the garage.

Simply use one of the 3 keys supplied to operate the door.

The unit has a convenient blue LED indicator.



Figure 6
WB-1
Wireless
Wall Button

WB-1 is a convenient radio control unit to operate your door from an alternative position within your garage.

One, two or three channel versions are available.

The unit has a convenient blue LED indicator.

3 Fitting the RS- I Control Unit

3.1 The RS- I control unit is normally fitted on the same side as the motor drive. Select a suitable position for the control unit, within sight of the door, well away from moving parts, ensuring that:-

- It can be plugged into an adjacent 13A switched socket.
- It is within the constraints of the motor lead, using a 'tidy' cable run.
- It is mounted with the built on lamp at the top.
- It is fitted at a height of at least 1.6 meters out of the reach of children.
- It is fitted inside a dry room only (I.P.44 rating)

3.2 Fitting the enclosure - Refer to fig 7

Remove the courtesy lamp lens from the base by squeezing the sides of the lens, disengaging the clip in the top of the lens. Remove any packaging from the lamp. Pull off the trim, and undo the two fixing screws approximately 20mm, noting that it is not necessary to completely remove the screws which remain attached to the cover. Carefully remove the cover by pulling it away from the base with a slight downward movement. The packing box lid provides a useful drill fixing template. Fix the base to the wall using the fixing screws and plugs provided.

Note: Do not allow dust to enter the unit which could damage the electronics.

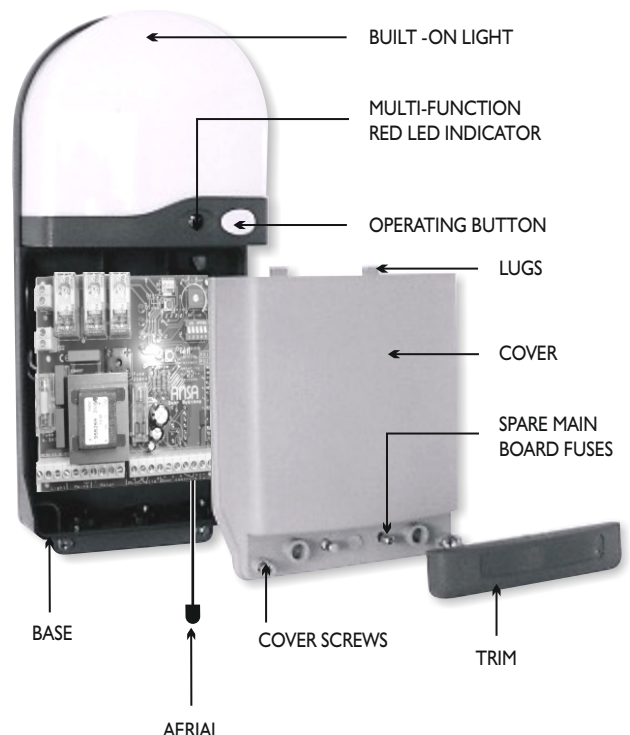



Figure 7

4 Electrical Connections

Always switch off the mains power supply before making any connections!. Electrical connections should be carried out by a competent person. If in doubt consult a qualified electrician! Cables should enter the control unit through the cable glands fitted to the bottom of the RS-I unit.

4.1 Power

The 240v ac input should be connected from an adjacent 13 amp 3 pin switched socket. The plug must be fitted with a 5 amp fuse. Connect the power supply to terminals marked MAINS, N, L, 

4.2 Motor

Connect the motor lead to the terminals marked MOTOR, E, L1, L2, N3. The blue motor neutral cable must be connected to the terminal marked N3. Connect the yellow/green earth cable to the terminal marked E. Connect the brown and black motor power cables to terminals L1 & L2. Ensure that motor direction matches the open and close LEDs and if necessary interchange the motor cables at terminals L1 & L2 (See figure 9).

4.3 Adding Lighting

Terminals marked LIGHT, E, L, N, provide a 240 volt ac lighting output which functions the same as the built on light. Lighting switches on for 3½ minutes whenever the door is operated and turns off automatically. Maximum load 400 watts.

4.4 Connecting The Roll-Smart track(s)

- Connect the blue wire(s) to 0V
- Connect the brown wire(s) to 12V
- Connect the Roll-Smart track one green wire to RA1
- Connect the Roll-Smart track two green wire to RA2

4.5 Connecting a Photoelectric Cell System (optional)

Remove the factory fitted link connecting PEC and 12V

- Connect the blue wire to 0V
- Connect the black wire to PEC
- Connect the brown wire to 12V (Connections are for the ANSA PEC-3 Photocell Unit)

4.6 Connecting a Push Button (Hard Wired)

A push to make (normally open) push button or key switch can be connected to terminals COM & IMP. This provides an OPEN - STOP - CLOSE - STOP sequential operation which works the same as the keyfob.

4.7 Connecting a Stop Push Button (Hard Wired)

A push to break (normally closed) push button or key switch can be connected to terminals marked COM & STP. Activation will stop the door immediately regardless of it's position. Remove the factory fitted link connecting COM & STP.

4.8 Fitting the Aerial. An external aerial is supplied which must be fitted as follows:

Pass the 135mm stainless steel wire aerial through the small hole in the base of the RS-I control unit alongside the right hand cable entry and connect to the terminal marked "EXT A". It is also possible to fit a 'remote' aerial. Connect via coax cable with the inner wire core connected to terminal "EXT A". Separate the screen from the wire core and connect to terminal "OV", and strip off 135mm of the screen at the free end.

4.9 Fitting the optional ANSA Alarm System (Type ALI8)

Fix the alarm module alongside the left hand side of the RS-I Unit. Pass the connection lead through the right hand cable entry gland and connect the plug to the security alarm socket on the RS-I circuit board (see figures 8 and 16).

The system is activated by the Roll-Smart system in the event of a break in attempt.

Note: The alarm unit has two volt-free normally closed terminals which can be optionally connected directly to the home alarm system. The normally closed circuit switches to open circuit in an alarm triggered condition.

5 RS-I Control Board Overview

Figure 8

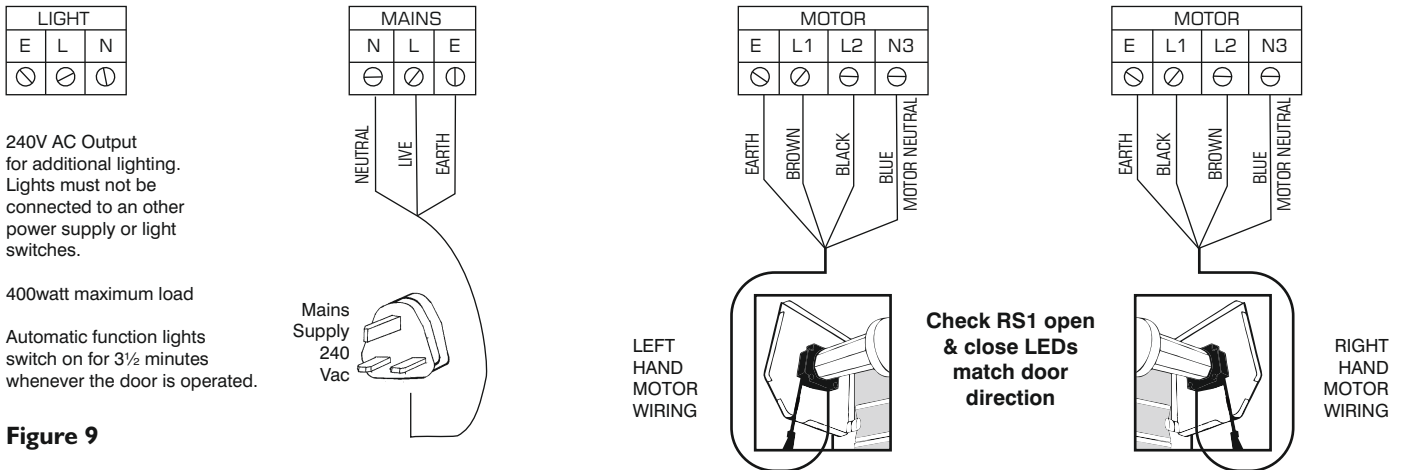
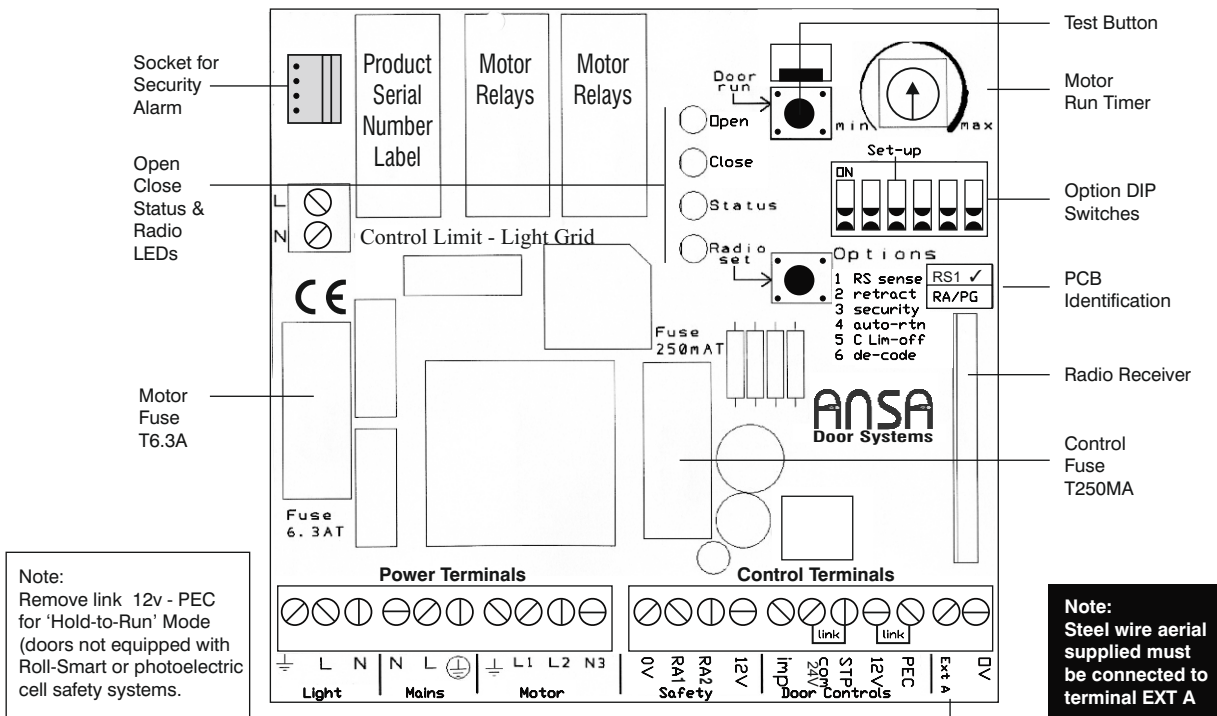

Figure 9

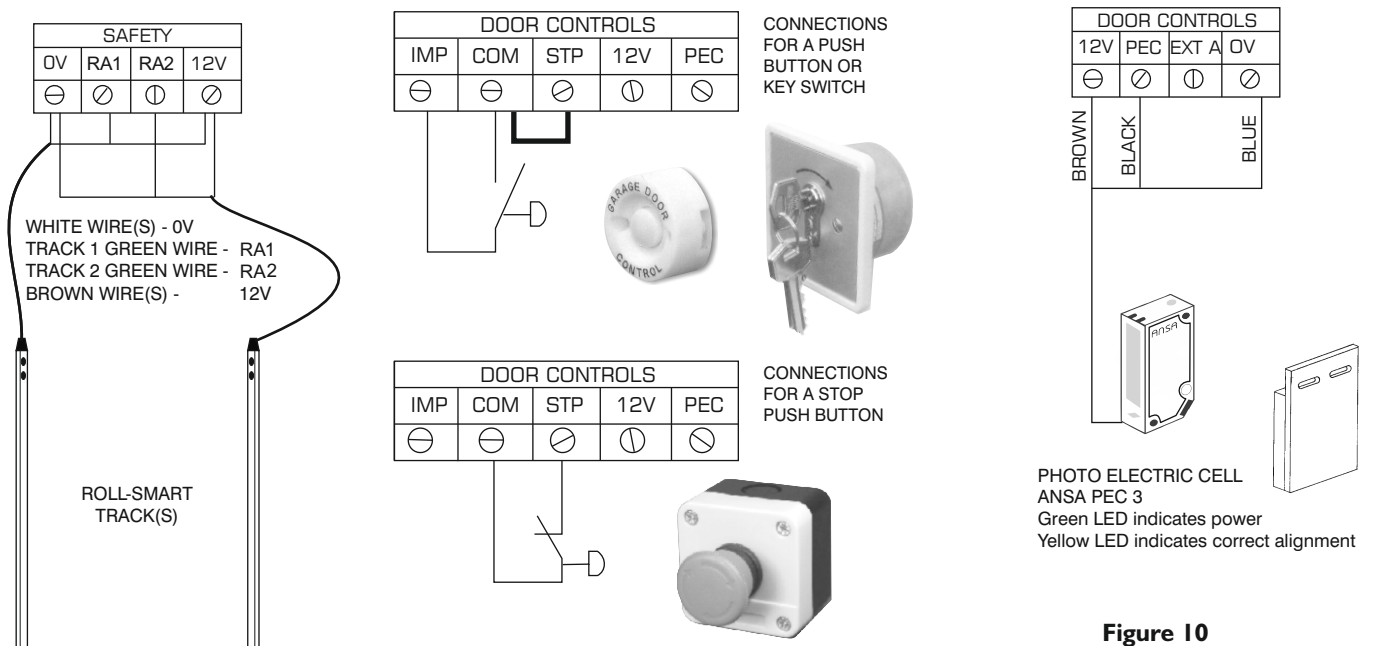

Figure 10

6 Roll-Smart System (optional)

6.1 Function

The Roll-Smart System from ANSA is designed specifically to equip lightweight aluminium roller doors with a safe, effective, reliable and CE compliant safety system. The unique Roll-Smart system is patent pending (number GB1803931.3)

Single sized doors use a single Roll-Smart track and heavier double sized doors require two Roll-Smart tracks. The active safety system is designed to monitor the closing operation of Roller Doors equipped with an ANSA RS-I control unit. The Roll-Smart track(s) are mechanically fixed directly to the door guide tracks and electrically connected (low voltage) to the ANSA remote control unit. The Roll-Smart track(s) contain multiple electronic sensors which together with magnetic sensor(s) fitted to the roller door bottom rail enable the RS-I microprocessor to safely scan the closing movement of the roller door and detect any obstructions in the path of the closing door, safely reversing the closing movement. The compact and robust design with a cross section of only 22mm x 13mm provides minimal intrusion into the garage space. Status LED indicators are fitted to the Roll-Smart track(s) and RS-I unit for easy installation.

Figure 12 Typical single Roll Smart track installation

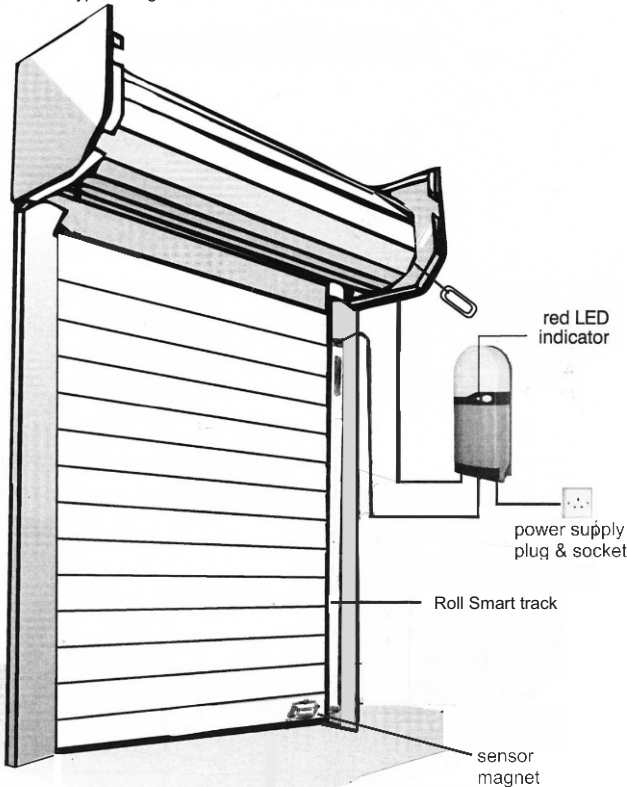

6.2 Installation - The Roll-Smart system must be fitted in the sequence A to G as below

A) Fit the RS-I control unit in position. Make sure that the motor lead, Roll-Smart track lead and mains power supply socket are within reach.

B) Connect the motor cable to the RS-I unit (see fig 9 page 4). Do not connect the Roll-Smart track lead at this stage!

C) Switch on the mains power supply and commission the motor limit switches. (see section 9 page 8)

D) Open and stop the door with the bottom rail at chest height and switch off the mains power supply.

For reliable operation it is essential that the magnet sensor is fitted in the correct position. Carefully move the door curtain and bottom rail over so that there is no free play at the back of the door guide and mark the bottom rail with a pencil in line with the inner edge of the door guide. The sensor magnet should be fitted 10mm further away from this pencil line position.

E) Switch on the power supply and close the door onto the floor. Ensure the face of the door guide is clean and wipe off any dust.

The Roll-Smart track is fitted level with the bottom of the sensor magnet and in line with the inner edge of the door guide.

Peel off the film fitted to the adhesive tape on the back of the Roll-Smart track and fix the track to the door guide.

Fully open the door and switch off the mains power.

F) Connect the Roll-Smart track(s) as per the diagram Fig. 10

Fit the remote control aerial (see 4.7 page 3)

The door is now ready for commissioning.

G) Commissioning: Fully open the door and switch off the mains supply. Connect the Roll-Smart track lead to the RS-I control unit as per fig. 10 page 4 and then switch the mains supply back on. To commission press the RS-I operating button for one second, wait 2 seconds and then press the RS-I button again and the door will close. The door should stop just before it touches the floor and then partially re-open, confirming correct set-up. Note - Do not stop the door during the door close set-up cycle. If you make a mistake simply open the door and repeat the door close procedure.

6.3 Testing

Place a strong box in the centre of the doorway and deliberately close the door onto this obstruction. The door should automatically stop and safely re-open. Note - there is a short delay built into the system.

Note. If the door re-opens during tests for no apparent reason, switch off the mains power and switch on DIP option switch No. 1 (see fig.8 page 4) which increases the system response time.

6.4 Roll-Smart system re-set

A system re-set may be needed to clear commissioning errors or where a new RS-I PCB or Roll-Smart track has been fitted.

Open the door and undo the RS-I "stop" terminal and adjust the PCB link so that the RS-I status LED switches from green to red.

Switch off the power supply and press the PCB door run button continuously, then switch on the mains power supply and observe the RS-I red LED indicator which should flash off and on slowly.

Tighten the RS-I "stop" terminal and ensure the RS-I status LED switches back to green.

Switch off the power supply for 5 seconds to complete the re-set procedure. Commission as per 6.2 (G) above

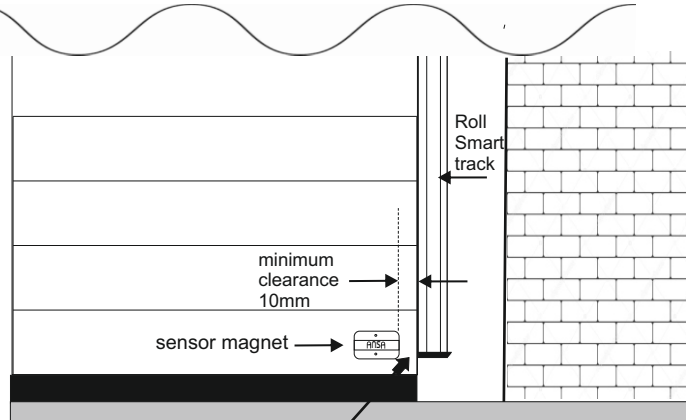

Note:

Fix the Roll-Smart track level with the bottom of the sensor magnet and in line with the inside edge of the door guide.

A minimum clearance of 10mm is required with zero play between the curtain end-locks and the back of the door

7 Photoelectric Cell Safety System (optional)

7.1 Function

The ANSA photoelectric cell (PEC) projects an invisible infra red beam across the door opening which is focused on a reflective lens target. Obstructions within the doorway blocking the safety beam are sensed and a safety signal is transmitted to the RS- I Control unit

- The safety beam has no effect on an opening door.
- Breaking the safety beam prevents closure of an open door and will also stop and re-open a closing door.
- The option to fully or partially re-open the door is a DIP Switch Option (see I 5.2, page 9).

The RS- I Control Unit continuously monitors the photoelectric sensor. If a fault or obstruction is detected the system prohibits closure of the door, this is indicated by the multi function red LED which will flash quickly. Closure of the door is then only possible in "hold to run" mode (see section 2.4)

7.2 Testing

With the photocell correctly adjusted and working the green and yellow LED's fitted to the sensor and the red indicator LED fitted to the RS-I control unit will be illuminated. Breaking the photo-beam will switch off the yellow LED fitted to the sensor and cause the red indicator LED to flash quickly, confirming correct operation. Once a month check the system for correct operation. using a keyfob, stand inside the garage and close the door and whilst it is moving - block the photobeam using a piece of cardboard or similar. The door should stop and then reverse to the fully open position.

7.3 Installation (Refer to figure I 1)

Fix the photo cell brackets to the door guides at a recommended height of 300mm using the self-drilling screws provided. Fit the photoelectric sensor to the pivot bracket using 2 noM4 x 35mm nuts and bolts provided ensuring that the flat and shake proof washers are correctly fitted. Attach the pivot bracket to the photocell bracket using 2 no M4 x 15mm nuts and bolts provided. Fit the photocell reflector to the opposite bracket using 2 noM4 x 15mm nuts and bolts provided. The diagram shows a right hand installation. The photo sensor can be fitted left hand using a similar assembly.

7.4 How to align the photoelectric sensor (ANSA Type PEC-3)

The green LED is illuminated when the photoelectric cell is switched on. For reliable operation it is important that the photo beam is "centred" on the reflector using the following set-up procedure. Adjust fixing screws A & B so that the photoelectric sensor and pivot bracket can be moved up and down and left to right. Move the sensor until the yellow LED flashes indicating that alignment is close. The yellow LED will illuminate steady when the sensor is correctly aligned. Tighten screws A & B in this position.

7.5 Maintenance

Periodically clean the PEC sensor lens and reflector with a damp cloth and wipe dry.

Please note: Before closing the door always check that the door opening is free from obstructions and do not leave objects in the path of the door.

The photoelectric cell sensor will not detect objects positioned below or above the infra red beam. No one should enter or leave the garage while the door is in motion.

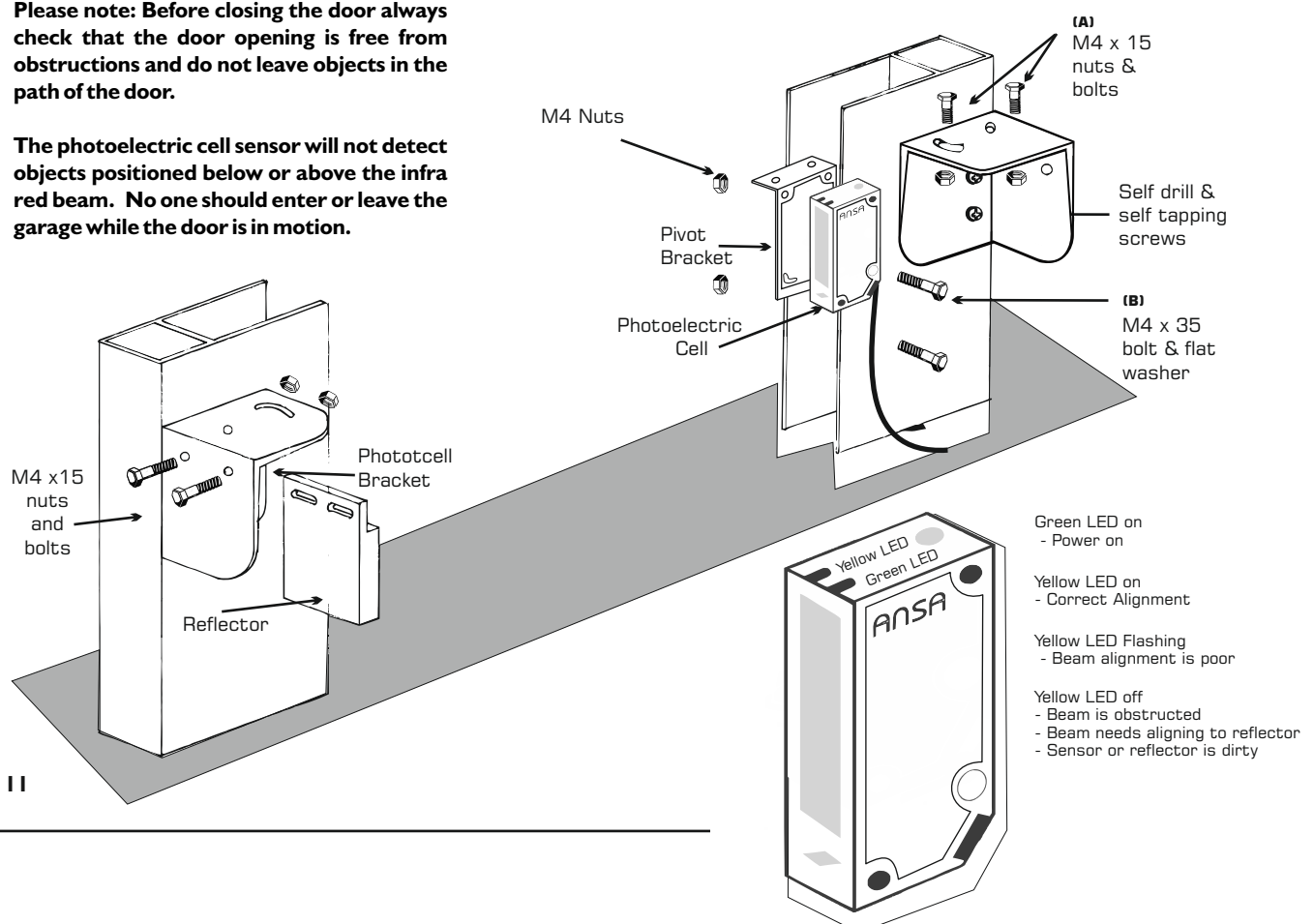

Figure I 1

8 Alarm System - Type AL-18 (optional)

8.1 Function

The AL-18 system is an intruder alarm designed to protect an attempted break in through the garage door. The system automatically arms when the door is closed and is automatically disarmed whenever the door is opened using the keyfob transmitters or other access controls. The alarm module is fitted with a 90db siren and alarm status indicator. The alarm module is also equipped with volt free terminals which provide the option to connect the system direct to the main house alarm.

The alarm works together with the Roll-Smart system to detect if an attempt is made to force open the door.

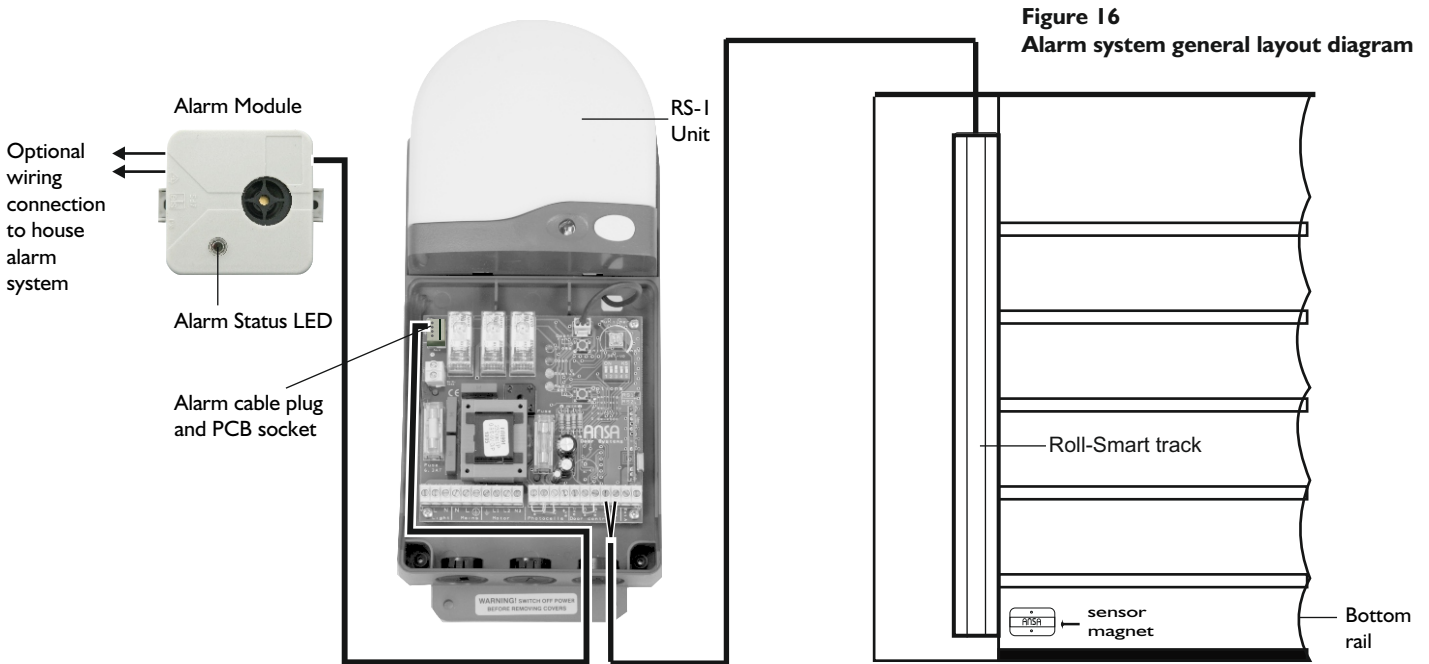

8.2 Installation

- **Fitting the alarm module**

Fix the Alarm Module to the left of the RS-I Control Unit using the plugs and screws provided. Pass the connection lead and plug through the right hand cable gland entry and route the cable as shown away from the radio receiver tile and connect the plug to the alarm socket on the RS-I circuit board. NOTE - Do not fit the Alarm module next to the Radio receiver tile.

8.3 Operation

The unit automatically arms on closure. A 'break in' alarm signal is transmitted if the bottom rail is forced open due to interruption of the magnet and transmitter. Note the alarm automatically resets 15 minutes after it is activated.

8.4 Testing

Wait at least 1 minute after the door closes for the system to arm. Use the manual override to raise the door slightly. The alarm should activate (90 DB sounder). Operate the keyfob to switch off the alarm.

8.5 Alarm LED Status Indication

Green ON	- Door is closed and Alarm system is SET
Red ON	- Door is open and Alarm system is OFF
Red / Green Flashing	- Door is opening or closing or is part open

8.6 Optional connection to main house alarm system

The ANSA AL-18 Module is equipped with volt free normally closed terminals for optional direct connection to the main house alarm system. A break in attempt will cause the ANSA alarm and house alarm to activate simultaneously.

9 Commissioning

The tubular geared motor supplied with your door has integral electro-mechanical limit switches that cut off the power to the door motor when the door is at the fully open or fully closed position. For reliable & safe operation of the door, **the motor limit switches must be accurately set in accordance with information supplied by the door manufacturer.** The following general guidelines may be helpful. Before you operate the door electrically you may want to operate the door slowly using the manual override provided to ensure that the door will not catch on any protrusions as it travels up and down.

Somfy Motor Drives have the advantage of commissioning using the manual override to set the motor limits and to make final adjustments which provides far greater control of the door as it travels up and down.

9.1 Doors Equipped with Somfy Motor drives

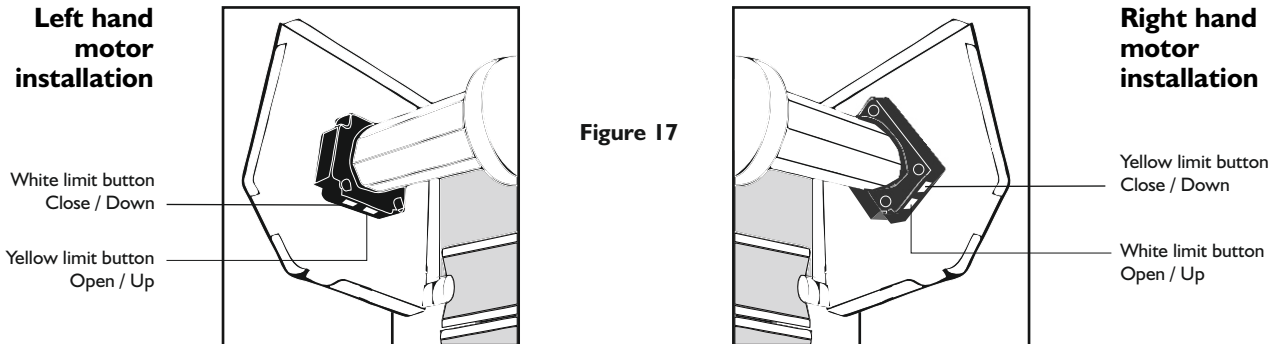

- To set the motor limits, remove the cap covering the white & yellow limit switch buttons and fully press in both switches (they will lock in the depressed position).
- Wind the door down using the override handle so that the door locking system is set in accordance with the door manufacturers instructions. Press and release the door close / down limit button so that it 'pops out' to memorise this door close position.
- Wind the door open using the override handle so that the door fully open position is set in accordance with the door manufacturers instructions. Press and release the door open / up limit button so that it 'pops out' to memorise this door open position.

Note - Always replace the limit switch cover cap once the limits are set.

9.2 Doors equipped with Tubular Motor Drives with Screw Limit Switch Adjusters

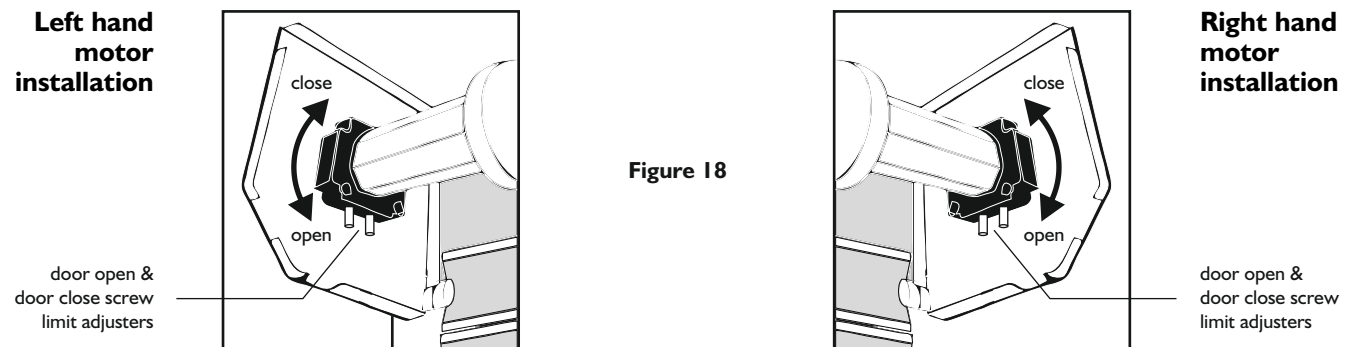

- Adjustment of screw type limits is carried out with the power supply switched on.. Use extreme caution to avoid personal injury or damage to the door and **always follow the door manufacturers specific instructions.**
- Adjustment is carried out by rotating two screw adjusters fitted to the motor. Carefully study the door manufacturer's instructions so that the correct open and close adjuster is identified and the correct rotation of each adjuster to increase or decrease door travel is known.
- Use the override handle to position the door half open. The RS- I Control button is used to control the door (refer to Section 2.3) and Option Dip switch No. 3 on the RS- I PCB will need to be switched on when carrying out limit switch adjustments.
- Open and close the door ensuring that at no time does the door curtain raise out of the door guides or over-travel when closing which could cause personal injury or damage to the door.
- Carry out fine adjustment of the limit switches in accordance with the door manufacturers instructions, noting that the door could move slightly when the adjusters are being rotated.
- When the limit switches are correctly set turn off Dip switch 3 for normal operation. See fig 19

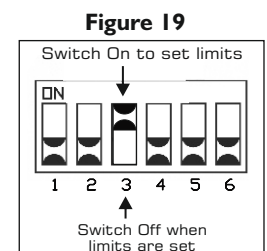

NOTE - Ensure that the motor direction matches the open and close RS- I circuit board LED's, if necessary switch off the mains power supply and interchange the motor cables at L1 and L2. **Note:** the motor unit has an inbuilt thermal trip which activates if the motor gets too hot after repetitive use, causing the motor to cut out. If the thermal trip operates wait approximately 20 minutes for the motor to return to normal operating temperature.

10 Adding Transmitters & Wireless Access Controls

Keyfobs supplied are normally preprogrammed. Extra keyfobs or other wireless access control devices are added as follows. Press the RS-I control button for 5 seconds and release when the red LED indicator goes out. The LED will flash once to confirm Add Mode. Take the new transmitter to be added and press the button once. The RS-I red LED indicator should flash once. Repeat this for every new transmitter to be added to the system. After the last transmitter has been added either wait 30 seconds or press the operating push button once to reset to normal operation. The remote control system uses the latest "rolling code" technology. The receiver can memorise the codes of 26 transmitters. Upgrade memory chips are available for 31 or 62 transmitters by special order.

11 Deleting Transmitters & Wireless Access Controls

It is not possible to selectively delete transmitters and selecting delete mode will erase all transmitters from the system. Temporally switch off DIP 1 (if selected) when deleting. Switch off the power supply to the unit and remove the front cover. Turn on Dip switch 6 and re-power the unit. The circuit board mounted yellow "set radio" LED will illuminate for 5 seconds, all transmitters are now deleted. Switch off the power supply, turn off Dip switch 6 and re-fit the front cover. Transmitters (and other wireless access controls) can now be reloaded using the "Add Transmitters" procedure.

12 Multi-Door Control

Four types of Transmitters are available, 1, 2, 3 or 4 buttons, therefore up to four doors each fitted with a standard RS I control unit can be controlled independently using a single transmitter. Simply select the transmitter button you wish to use with a particular door and programmes the transmitter as per section 10 "Adding Transmitters".

13 Holiday Mode

In some instances it may be helpful to switch off the controls operating the door temporarily without turning off the mains power supply or erasing transmitter security codes. [For example during holiday periods] To activate this feature simply press and hold the operating button for approximately 12 seconds and wait until the red indicator LED flashes slowly. To return to normal operation switch off the power supply to the control unit for five seconds and then switch back on.

14 Fault Diagnostic System

The microprocessor monitors the circuit board, low voltage control wiring, control devices connected to the system and safety systems and detects possible faults. If a fault is detected the door cannot be operated and the red LED will flash slowly. The power supply should be switched off until the fault is found and corrected

15 Dip switch options & Special settings

The RS-I control unit has six onboard Dip switches which control the following features.

15.1 Dip switch 1 Roll-Smart sensitivity When switched on increases the Roll-Smart response time.

15.2 Dip switch 2 Retract. When switched on, selects partial retract. If the photocell system is activated, the door retracts 200mm instead of returning to the fully open position.

15.3 Dip switch 3 Security. When switched on, extends the motor supply feed for the duration of the motor run timer which assists adjustment of screw type motor limit switches Dip switch 3 is normally turned off. Additionally for doors having an externally fitted manual override system, switching on Dip switch 3 selects a security system. If the manual override system is used to force open the door, the system will power down the door to the closed position.

Note - When using the security system it is important to accurately set the motor run timer. operate the door from the fully closed to the fully open position and adjust the run timer so that the circuit board "open" LED goes out five seconds after the door arrives at the fully open position. See Figures 21 and 22.

15.4 Dip switch 4 Auto- Close. This option is normally turned off. Turning on Dip switch 4 selects an automatic time delay self closing function. The time delay begins when the door is fully open and is reset if the photoelectric safety beam is activated. The auto-close delay is dependant upon door size and operating speed. Set the motor run timer as described in "security", the corresponding auto close delay is shown in Fig 10.

Note; Selecting Auto-close increases the level of automation and to comply with relevant safety standards we recommend autoclose is only used with doors having the Light Grid System.

15.6 Dip switch 5 Generator Mode / Motor Current Sensing System Off.

When switched on the control may be able to operate using a portable power supply generator and for small doors Dip switch 5 will also switch off the Motor current sensing (anti-entrapment) system.

15.6 Dip switch 6 Decode. Used when removing lost or stolen keyfobs from receiver memory (See section 11 - deleting transmitters).

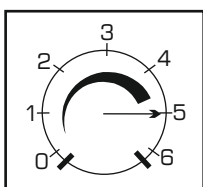

Figure 21

NOTE:
Position 5
is the standard
factory setting

Timer Setting	Motor Run Time (seconds)	Auto close Delay (seconds)
0	2	10
1	8	18
2	16	34
3	26	46
4	35	60
5	44	70
6	52	90

Figure 22

Run Timer Settings

16 Problem Solving Guide

Note - Always switch off the power supply before attempting to repair the door or control system!

RSI LED Signal	Door Status	Cause	Solution
LED On	Operational	No fault	Door in stand-by mode
LED Off	Door is not operational	<u>Power supply fault</u> Fuse in plug has blown PCB fuses have blown Other fault	Test mains power supply and switch on. Reset circuit breaker Replace 5amp fuse in 3 pin plug (or spur unit) Replace PCB main fuse (coloured white) 6.3amp 5mmx20mm Replace PCB control fuse (clear) 500ma 5mmx20mm (note: spare fuses are fitted to RS-I cover - See figure 7, page 2) Possible PCB failure - Contact your Installer
LED On	Door is not operational	<u>Possible Motor Fault</u> Motor thermal trip has activated Motor limit switches need to be set Possible motor fault has developed	Allow door motor to cool for approximately 20 minutes before attempting to operate the door Adjust or set motor limit switches in accordance with door manufacturers instructions Close door with manual override. Switch on dip switch number 3. Try to operate door using RS-I control button. A possible motor fault is indicated if the door fails to operate but the door open and door close LEDs illuminate. If so - Contact your Installer
LED flashing rapidly 3 times, gap, repeating	Door opens but will not close (doors with Roll-Smart Safety System)	Roll-Smart Track GREEN LED is ON Roll-Smart Track GREEN LED is OFF	Check Roll-Smart sensor magnet position Check all Roll-Smart track cable connections are secure Check that Roll-Smart commissioning has been carried out in line with 6.2 F Check all Roll-Smart track cable connections are secure * If no fault is found - Contact your Installer - Door can be closed using 'hold-to-run' mode (see Figure 2.4, page 2)
LED flashing rapidly	Door opens but will not close (doors with photocell safety system)	<u>Possible Safety System Fault</u> Photoelectric cell (PEC) beam is obstructed Green PEC LED is ON & yellow PEC LED is off or flashing	Remove any obstacles in the doorway Ensure the Photoelectric cell and Reflector are clean Check alignment of the Photoelectric cell * If no fault is found - Contact your Installer - Door can be closed using 'hold-to-run' mode (see Figure 2.4, page 2)
LED On	Door is operational but sometimes re-opens when closing	Photoelectric cell problem Roll-Smart System problem	Check that Photoelectric cell brackets are secure Check Photoelectric cell alignment Check that the Roll-Smart sensor magnet is correctly fitted Switch on DIP option switch No. 1 (see fig. 8 page 4) which increases the system response time
LED flashing slowly every 2 seconds	Door is not operational	Stop circuit is activated Additional push button control is of the wrong type or has a wiring fault RS-I control button is faulty	RsI PCB status LED should be in green. If it is red - check that the PCB link (or Stop push button) connected to terminals COM and STP is correctly installed Do not connect push buttons having neon illumination Push buttons should be 'push to make' type Check for short circuit in push button or wiring Check RS-I control button operation. Button should click when pressed. If no fault is found - Contact your installer
LED On	Door stops randomly at any height	Motor current sensing system is activated	Switch on DIP switch 5 (see 15.6 - page 9)
LED On	Door is operational but has reduced range from keyfob transmitter	Battery in transmitter is weak - keyfob LED is dim Aerial has not been fitted to RS-I control unit	Renew keyfob transmitter battery Install steel wire aerial (see 4.7, page 4 and Figure 3, page 5)

17 Technical Specifications

Supply Voltage	220-240 VAC	Accessory Power Supply	24VDC --150 Ma
Transformer Power	3 VA	Control Logic	Eeprom microprocessor.
Power Relays	12 A - @ 230 VAC	Safety Input	NPN
Operating Temperature	-15 to +55 deg.C	Frequency	433.92 MHZ Super Hetradyne
Enclosure Rating	IP 44	Security-Rolling Code	Keeloq
Courtesy light	28 watt halogen (40 watt maximum)	Dimensions	300mm H x 130mm W x 74mm D

Roll-Smart patent pending - GB1803931.3

Door Manufacturer



GLIDEROL
GARAGE DOORS

Kitching Road,
North West Industrial Estate,
Peterlee,
Co. Durham,
SR8 2HP.
Tel: 0800 834 250

Installation

Door / Contract Number:

Installer:

Telephone Number:

Company:

Installation Date:



ANSA Door Systems Ltd

ANSA House, 17 Lawnswood Road, Wordsley, West Midlands DY8 5PE. Tel: 01384 293100 Fax: 01384 293200

e-mail: ansadoorsystems@btconnect.com Web Site: www.ansadoorsystems.uk

Technical Support Helpline: 0750 800 80 95

ANSA Door Systems Ltd. maintains a policy of continuous development and reserves the right to change the contents of this instruction guide without prior notice. The contents are intended for guidance only.